

SPECIFICATION SHEET

MODEL: UF-M

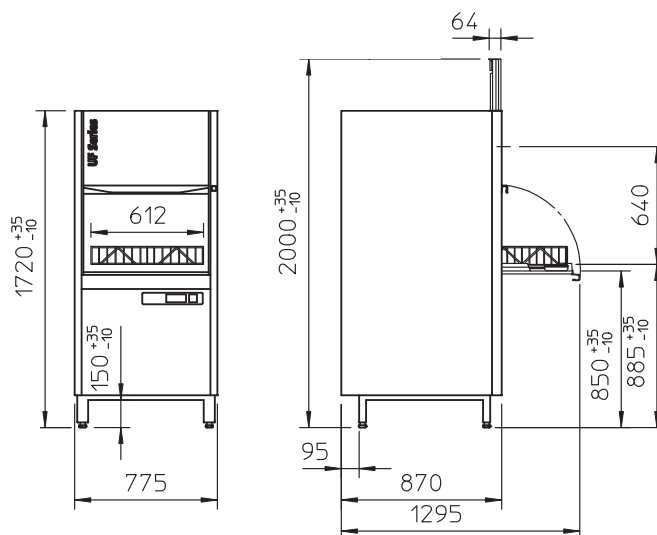

TECHNICAL INFORMATION

Dimensions	775w x 870d x 1720h
Rack Dimension	612 X 672
Clear Entry Height	640
Rinse Water Consumption	4.7L Per Cycle

WATER CONNECTIONS

Connection Point	3/4 inch (19mm)
Inlet Temperature	60c Max
Flow Rate	4 L/Min
Flow Pressure	1.0 bar/Min

ELECTRICAL

3 Phase (Standard)	415v 3P 50Hz - 32amp (TCL 18.7Kw)
3 Phase (Optional)	415v 3P 50Hz - 20amp (TCL 10.8Kw)

GENERAL DATA

Weight (Net/Gross)	190/220Kg
Tank Capacity	69L
Noise Emission	70dB(A)
Cycle Times	1.5, 2 & 5 Minutes

STANDARD INCLUSIONS

1x 3phase Lead
1x 1m Flexible Water Connection Hose
1x 1m Flexible Waste Hose
1x 612 x 672 Stainless Steel Rack

STANDARD FEATURES

- Touchscreen and colour- coded single-button control
- Quadruple wash water filtration
- Clouding sensor
- Active energy management
- Variopower washing pressure
- Fully insulated
- Drain pump
- Rinse booster pump
- Chemical pumps
- Optional drop down door